

MODEL SLIM

		FT50	FT60	FT75	FT100	FT150	FT200
CAPACITY	GAL.	50	60	75	100	150	200
	LIT.	189	228	284	379	570	760
WIDTH	IN	36	36	36	48	72	96
	CM	91.4	91.4	91.4	121.9	182.9	243.8
HEIGHT	IN	34	39	47	47	47	47
	CM	86.4	99	119.4	119.4	119.4	119.4
DEPTH	IN	12	12	12	12	12	12
	CM	30.5	30.5	30.5	30.5	30.5	30.5
WEIGHT	LB	144	163	182	231	329	358
	KG	62.4	74	82.6	104.8	149.3	162.4
NORMAL VENT	IN	2	2	2	2	2	2
EMERGENCY VENT	IN	2	2	3	3	3	3

TOP VIEW

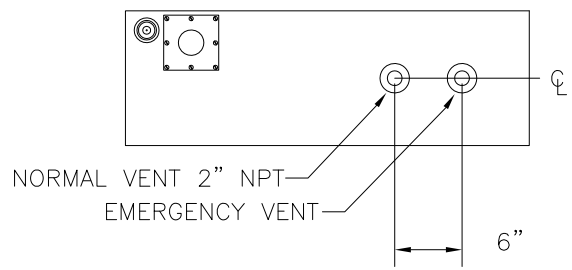

FRONT VIEW

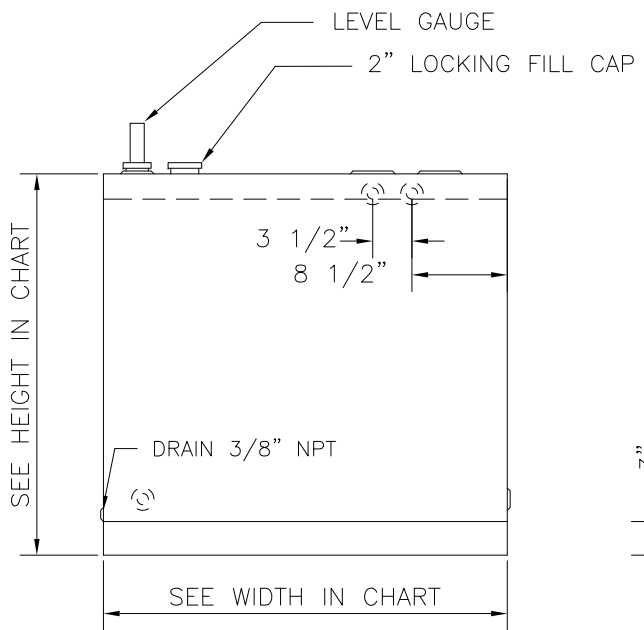

RIGHT SIDE VIEW

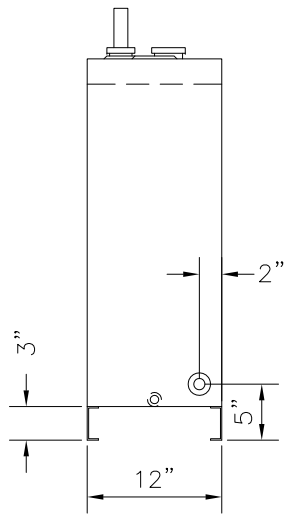

REAR VIEW

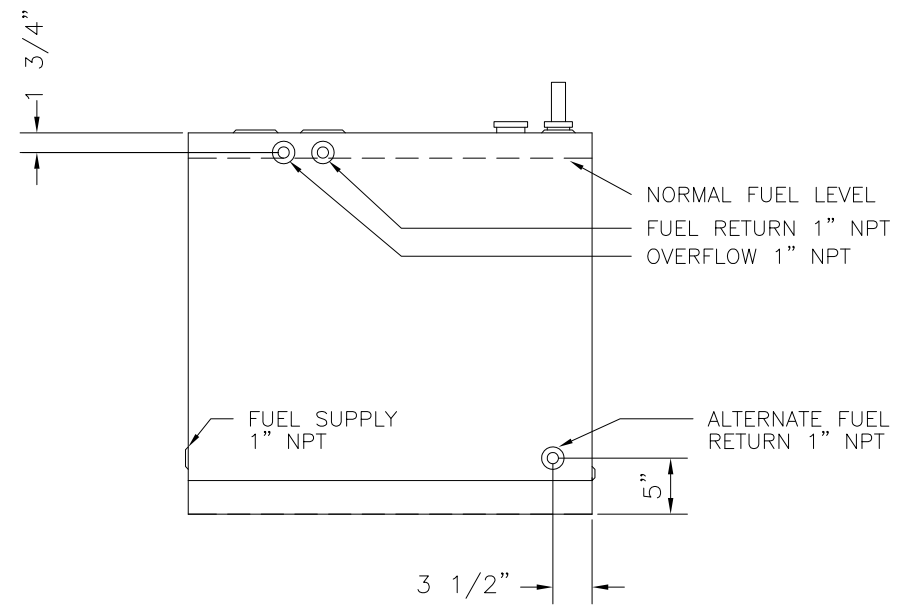

E & C A		
SCALE NONE	APPROVED BY	DRAWN BY: TMP
DATE 4-8-97		REVISED

REV	DATE	DESCRIPTION	BY	MODEL FT50,60,75,100,150,200	DRAWING NUMBER
1	12-13	MOVED NORMAL VENT TO TOP	MEP	SLIM TANK, UL DESIGN	03488