

TOP VIEW

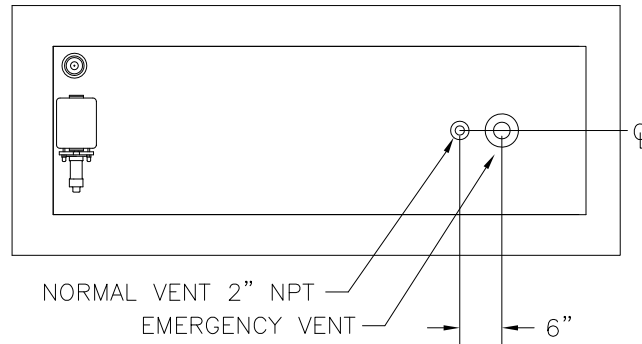

		MODEL					
		ET150	ET200	ET275	ET300	ET325	ET350
CAPACITY	GAL	150	200	275	300	325	350
	LIT	570	758	1041	1136	1230	1325
BASIN WIDTH	IN	36	36	36	36	40	36
	CM	91.5	91.5	91.5	91.5	101.6	91.5
BASIN DEPTH	IN	48	60	72	77	72	87
	CM	121.9	152.4	182.9	195.6	182.9	221
TANK WIDTH	IN	24	24	24	24	28	24
	CM	61	61	61	61	71.1	61
TANK DEPTH	IN	36	48	60	65	60	75
	CM	91.4	121.9	152.4	165	152.4	190.5
TOTAL HEIGHT	IN	50	54.5	54.5	54.5	54.5	54.5
	CM	127	138	138	138	138	138
BASIN HEIGHT	IN	33	35	40	40.5	42	42
	CM	83.9	88.9	101.6	102.9	106.7	106.7
WEIGHT	LB	546	665	860	911	917	1051
	KG	248	302	391	414	416	478
EMERGENCY VENT	IN	3	3	4	4	4	4

FRONT VIEW

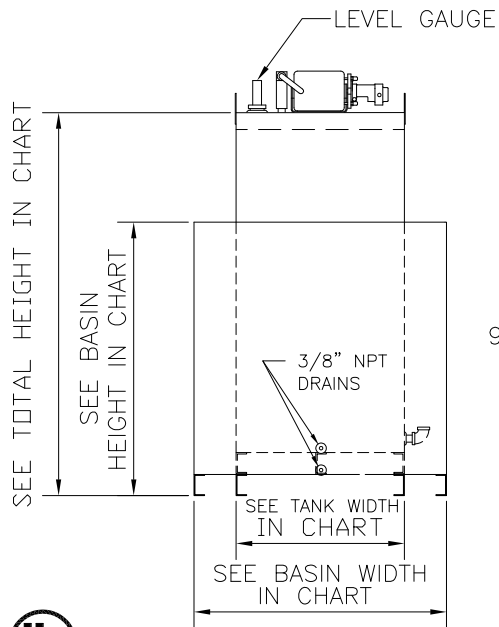

RIGHT SIDE VIEW

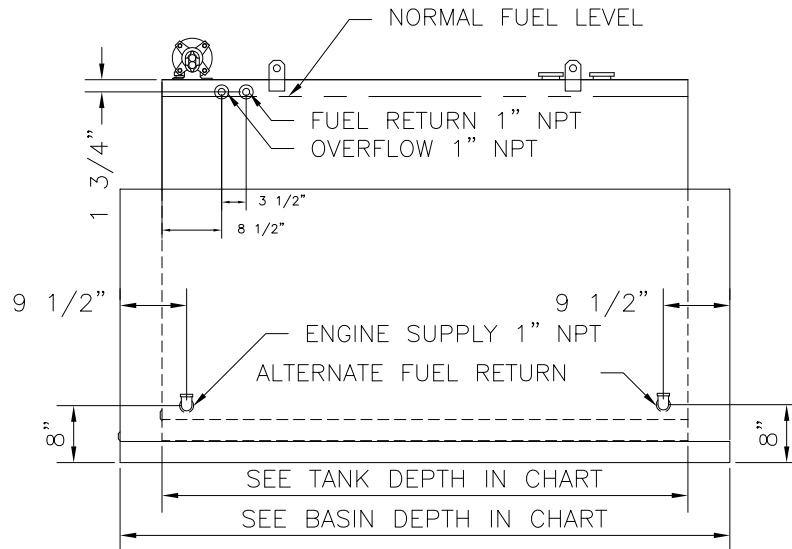

REAR VIEW

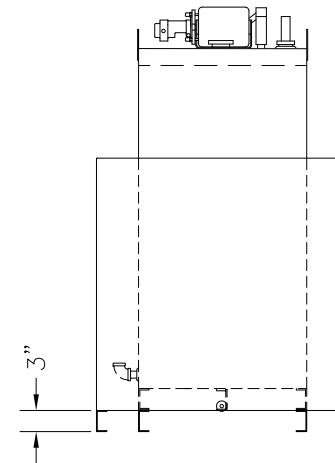

UL LISTED
FILE MH 15297
WHEN SPECIFIED

E & C A		
SCALE NONE	APPROVED BY	DRAWN BY: TMP
DATE 5-18-95		REVISED
ET150,200,275,300,325,350ULD		
w/ RUPTURE BASIN		DRAWING NUMBER 02839

REV	DATE	DESCRIPTION	BY
1	12-13	MOVED NORMAL VENT TO TOP	MEP