

TOP VIEW

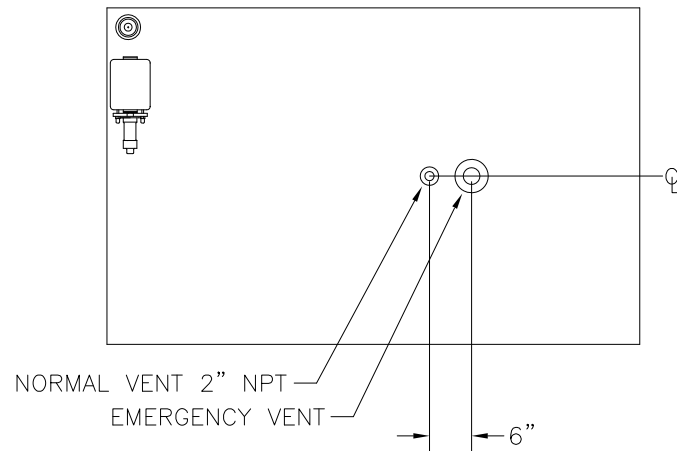

		MODEL			
		ET700	ET800	ET900	ET1000
CAPACITY	GAL.	700	800	900	1000
	LIT.	2660	3040	3420	3800
WIDTH	IN	48	48	48	48
	CM	121.9	121.9	121.9	121.9
DEPTH	IN	76	86	97	108
	CM	193	218.4	246.4	274.3
HEIGHT	IN	51.5	51.5	51.5	51.5
	CM	130.8	130.8	130.8	130.8
WEIGHT	LB	802	884	975	1065
	KG	365	402	443	484
EMERGENCY VENT	IN	5	5	5	5

FRONT VIEW

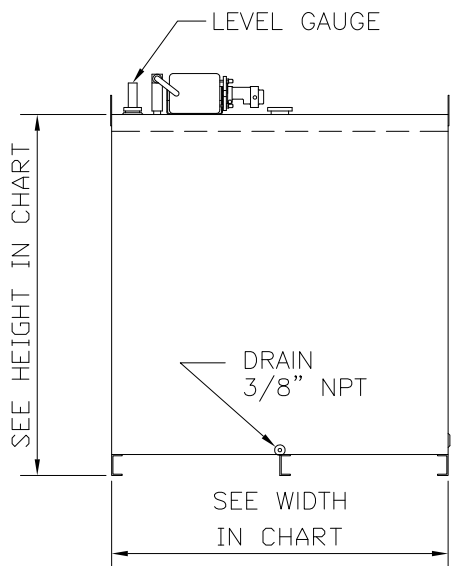

RIGHT SIDE VIEW

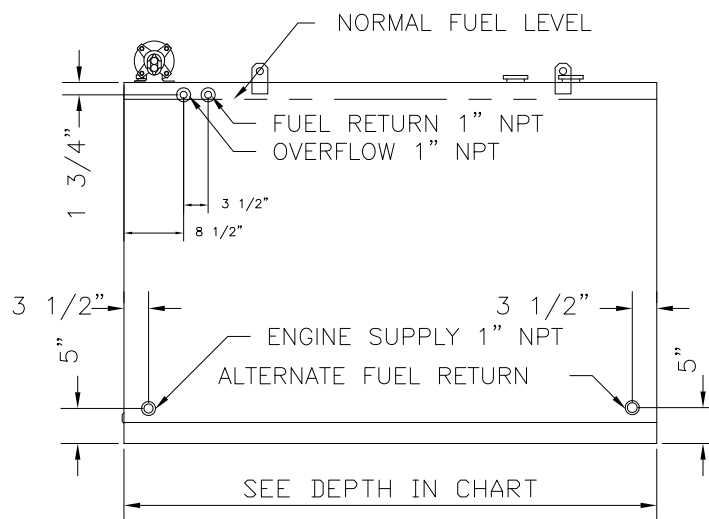

REAR VIEW

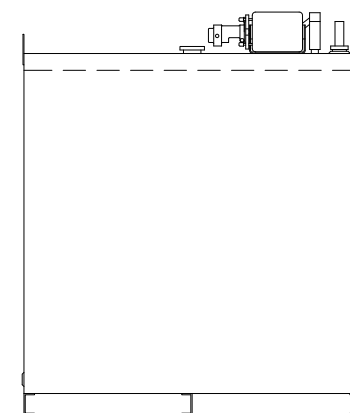

FILE MH 15297
WHEN SPECIFIED

REV	DATE	DESCRIPTION	MEP BY
1	12-13	MOVED NORMAL VENT TO TOP	MEP

E & C A		
SCALE NONE	APPROVED BY	DRAWN BY TMP
DATE 5-18-95		REVISED
ET700, 800, 900, 1000ULD		
UL DESIGNED TANKS		DRAWING NUMBER 02832