

FRONT VIEW

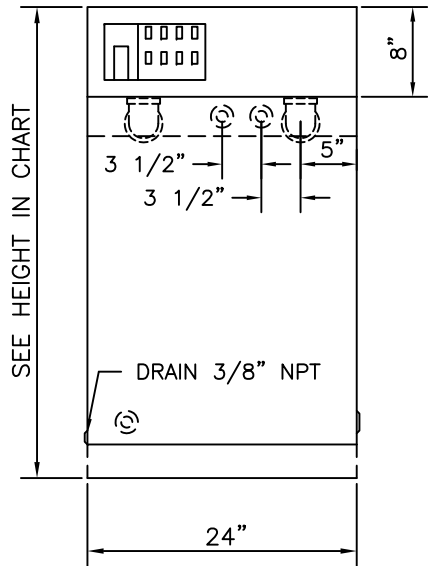

RIGHT SIDE VIEW

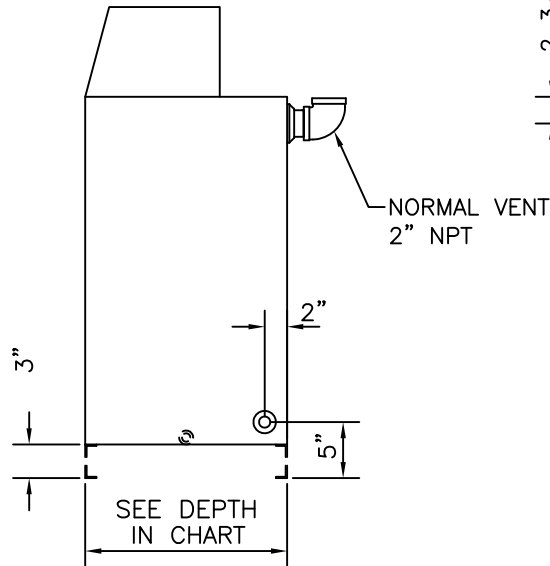

REAR VIEW

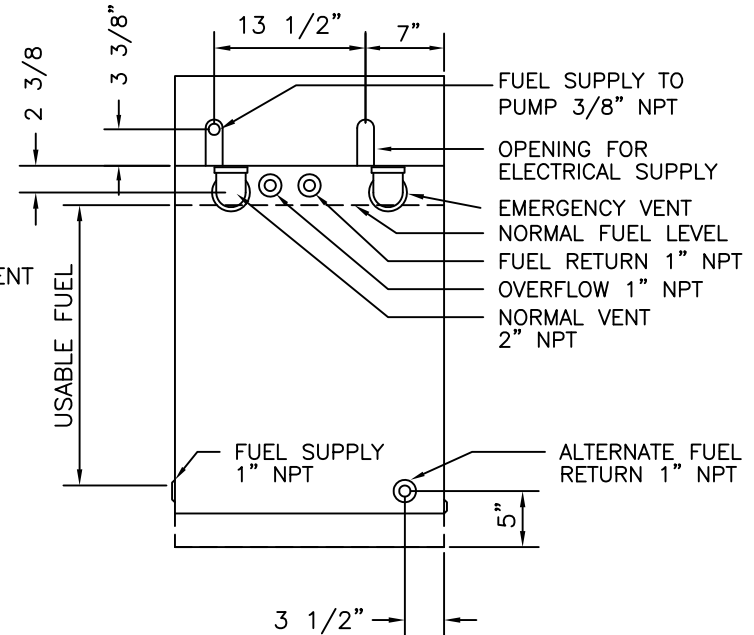

		MODEL			
		DT50	DT60	DT75	DT100
CAPACITY	GAL	50	60	75	100
	LIT	189	228	284	379
WIDTH	IN	24	24	24	24
	CM	61	61	61	61
HEIGHT	IN	42	47	55	55
	CM	106.7	119.8	139.7	139.7
DEPTH	IN	18	18	18	24
	CM	45.7	45.7	45.7	61
WEIGHT	LB	160	167	190	220
	KG	73	76	88.5	100
EMERGENCY VENT	IN	2	2	2	3



FILE MH 15297  
WHEN SPECIFIED

7	6-08	REMOVED HIGH/LOW ALARM LEVELS	KNA				
6	7-98	MOVED EMERGENCY VENT TO BACK	TMP				
5	3-96	ADDED UL LOGO	TMP		SCALE NONE	APPROVED BY	DRAWN BY: TMP
4	10-94	REMOVED NORMAL VENT	TMP		DATE 12-20-86		REVISED
3	4-94	ADDED EMERGENCY VENT	TMP				
2	10-93	VENT WAS 1" NPT	TMP				DT50ULD, 60ULD, 75ULD, 100ULD
1	10-93	ADDED 60 GALLON TANK	TMP				U.L. DESIGN DAY TANK
8	7-12	CHANGED VENT TO 2" NPT	MEP	1			DRAWING NUMBER 01424
REV	DATE	DESCRIPTION	BY	REV	DATE	DESCRIPTION	BY